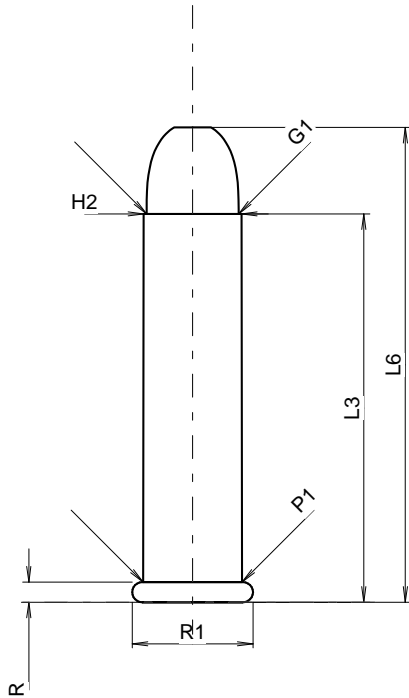

C.I.P.**22 Win. R.F. et 22 Rem. Spl.**TAB. **V**Date **84-06-14**Revision **00-06-07**

Country of Origin: US

**CARTRIDGE MAXI****Lengths**

L1	=	
L2	=	
L3 ¹⁾	=	24.51
L4	=	
L5	=	
L6	=	29.97

Case Head

R ¹⁾	=	1.27	-0.18
R1	=	7.62	
R3	=		
E	=		
E1	=		
e min	=		
δ	=		
f	=		
β	=		

Powder Chamber

P1	=	6.24
P2	=	

Junction Cone

α	=	
S	=	
r1 min	=	
r2	=	

Collar

H1	=	
H2 ¹⁾	=	6.18

Projectile

G1 ¹⁾	=	5.80
G2	=	
F	=	
L3+G ¹⁾	=	25.65

Pressures (Energies)**Method Crusher**

Pmax	=	1150 bar
PK	=	1323 bar
PE	=	1495 bar
M	=	26.31

Miscellaneous Dimensions

Fe ¹⁾	=	0.20
delta L	=	

CHAMBER MINI**Lengths**

L1	=	
L2	=	
L3 ¹⁾	=	24.89

Breech

R ¹⁾	=	1.27
R1	=	7.87
R2	=	
R3	=	
r	=	0.13

Powder Chamber

E	=	
P1 ¹⁾	=	6.25
P2	=	

Junction Cone

α	=	
S	=	
r1 max	=	
r2	=	

Collar

H1	=	
H2 ¹⁾	=	6.20

Commencement of Rifling

G1 *	=	6.20
G	=	1.14
α1	=	
h	=	
s	=	
i *	=	15°
w	=	

Barrel

F ¹⁾ *	=	5.59
Z ¹⁾	=	5.74

Grooves

b	=	1.76
N	=	6
u	=	356.00
Q	=	25.35 mm ²

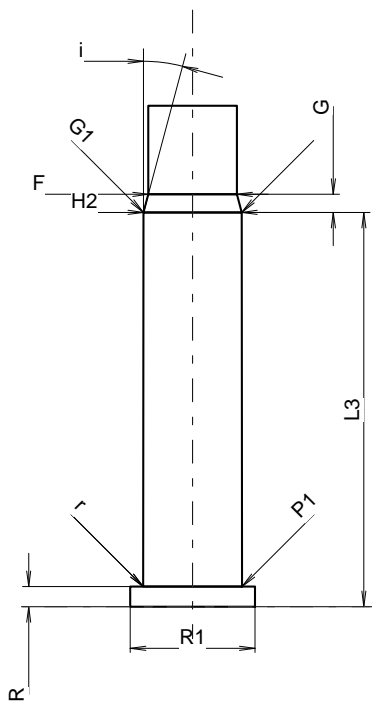

Scale 2.1:1

Dimensions in << mm >>
 Dimensions and Tolerances for Proof Barrels
 see Appendix CR 2.

Notes: 1) Check for safety reasons
 * Basic dimensions