

C.I.P.**400 H&H Belt. Mag.**

TAB. III

Date 05-05-25

Country of Origin: GB

Revision

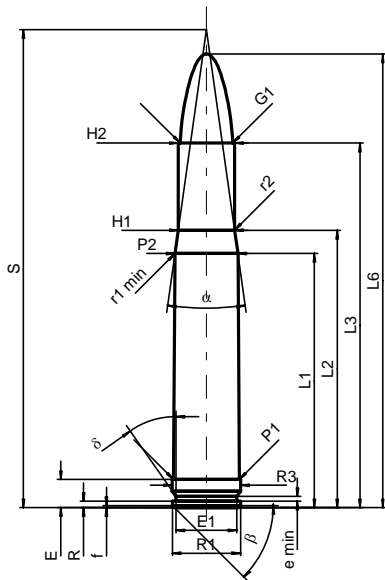
**CARTRIDGE MAXI****Lengths**

L1	=	50.40
L2	=	55.02
L3 ¹⁾	=	72.30
L4	=	
L5	=	
L6	=	90.00

Case Head

R	=	1.27
R1	=	13.51
R3	=	13.56
E ¹⁾	=	5.59
E1	=	12.07
e min	=	0.94
delta	=	35°
f	=	0.41
beta	=	45°

Powder Chamber

P1	=	13.03
P2*	=	12.50

Junction Cone

alpha*	=	16°01'01"
S*	=	94.82
r1 min	=	0.50
r2	=	0.50

Collar

H1*	=	11.20
H2 ¹⁾	=	11.20

Projectile

G1 ^{1)*}	=	10.44
G2	=	
F	=	
L3+G ¹⁾	=	82.26

Pressures (Energies)**Method Transducer**

Pmax	=	4400 bar
PK	=	5060 bar
PE	=	5500 bar
M	=	25.00
EE	=	6800 Joule

Miscellaneous Dimensions

Fe ¹⁾	=	0.10
delta L	=	

CHAMBER MINI**Lengths**

L1	=	50.24
L2	=	54.83
L3 ¹⁾	=	72.60

Breech

R	=	
R1	=	13.59
R2	=	
R3	=	13.59
r	=	

Powder Chamber

E ¹⁾	=	5.59
P1 ¹⁾	=	13.06
P2*	=	12.53

Junction Cone

alpha*	=	15°59'53"
S*	=	94.82
r1 max	=	0.50
r2	=	0.50

Collar

H1*	=	11.24
H2 ¹⁾	=	11.23

Commencement of Rifling

G1 ^{1)*}	=	10.45
G ¹⁾	=	9.96
alpha1*	=	90°
h	=	0.39
s*	=	5.95
i ^{1)*}	=	1°30'
w	=	

Barrel

F ^{1)*}	=	10.24
Z ¹⁾	=	10.44

Grooves

b	=	3.33
N	=	6
u	=	305.00
Q	=	84.39 mm ²

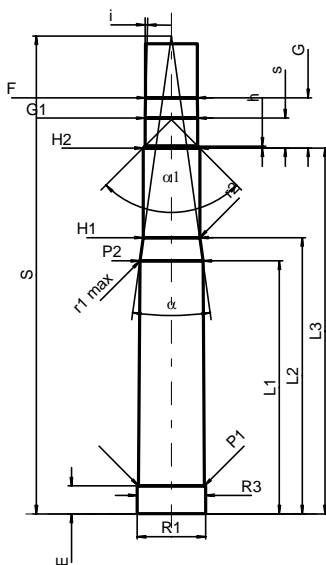

Scale 1:1.5

Dimensions in << mm >>
Dimensions and Tolerances for Proof Barrels
see Appendix CR 1.

Notes: 1) Check for safety reasons
* Basic dimensions