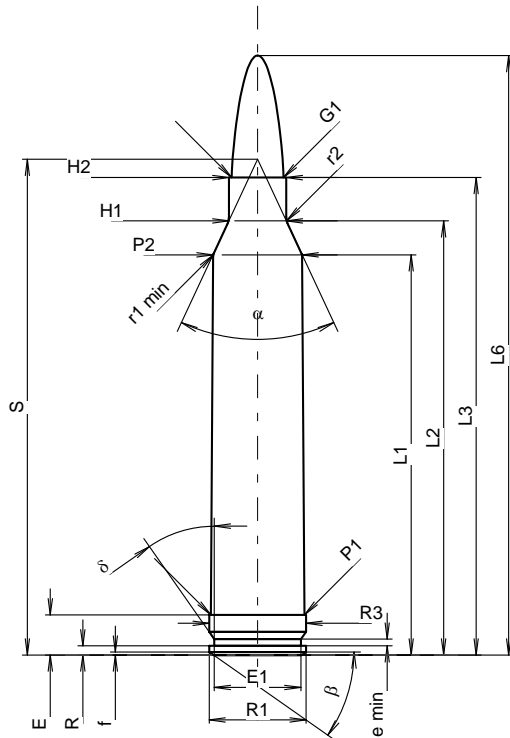

C.I.P.**7 mm Rosè**

TAB.	III
Date	17-05-17
Revision	

Country of Origin: IT

**CARTRIDGE MAXI****Lengths**

L1	=	55.78
L2	=	60.52
L3 ¹⁾	=	66.55
L4	=	
L5	=	
L6	=	83.57

Case Head

R	=	1.27
R1	=	13.51
R3	=	13.51
E ¹⁾	=	5.59
E1	=	12.07
e min	=	0.94
δ	=	35°
f	=	0.41
β	=	35°

Powder Chamber

P1	=	13.03
P2 *	=	12.42

Junction Cone

α *	=	50°
S *	=	69.10
r1 min	=	1.02
r2	=	2.54

Collar

H1 *	=	8.00
H2 ¹⁾ *	=	8.00

Projectile

G1 ¹⁾	=	7.22
G2	=	68.61
F	=	
L3+G ¹⁾	=	72.56

Pressures (Energies)**Method Transducer**

Pmax	=	4300 bar
PK	=	4945 bar
PE	=	5375 bar
M	=	25.00
EE	=	5000 Joule

Miscellaneous Dimensions

Fe ¹⁾⁵⁾	=	0.10
delta L	=	

CHAMBER MINI**Lengths**

L1	=	55.96
L2	=	60.62
L3 ¹⁾	=	67.16

Breech

R	=	1.27
R1	=	13.59
R2	=	
R3	=	13.59
r	=	

Powder Chamber

E ¹⁾	=	5.59
P1 ¹⁾	=	13.06
P2 *	=	12.45

Junction Cone

α ¹⁾ *	=	50°
S *	=	69.30
r1 max	=	0.76
r2	=	3.18

Collar

H1 *	=	8.10
H2 ¹⁾	=	8.08

Commencement of Rifling

G1 ¹⁾ *	=	7.23
G ¹⁾	=	6.01
α1	=	90°
h	=	0.43
s *	=	2.50
i ¹⁾ *	=	1°33'01"
w	=	

Barrel

F ¹⁾ *	=	7.04
Z ¹⁾	=	7.21

Grooves

b	=	2.79
N	=	6
u	=	241.00
Q	=	40.39 mm ²

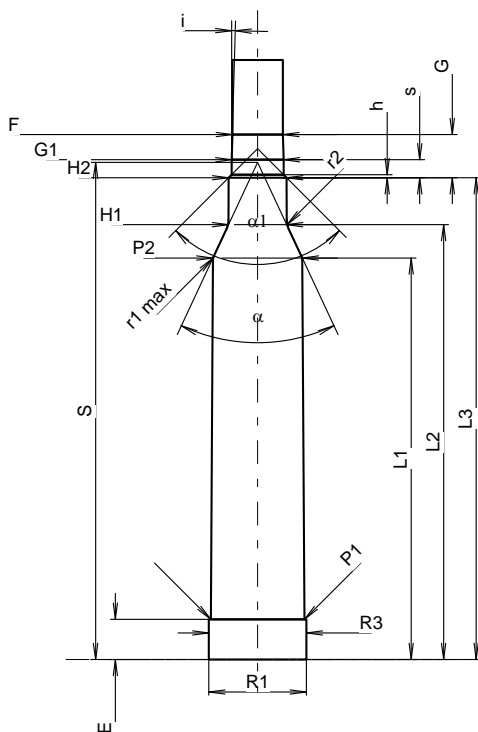

Scale 1:1.05

Dimensions in << mm >>
Dimensions and Tolerances for Proof Barrels
see Appendix CR 1.

Notes: 1) Check for safety reasons
5) Headspace on Belt
* Basic dimensions