

**C.I.P.****350 No. 2 Rigby**

TAB.

II

Date

84-06-14

Pays d'origine: GB

Révision

02-05-15

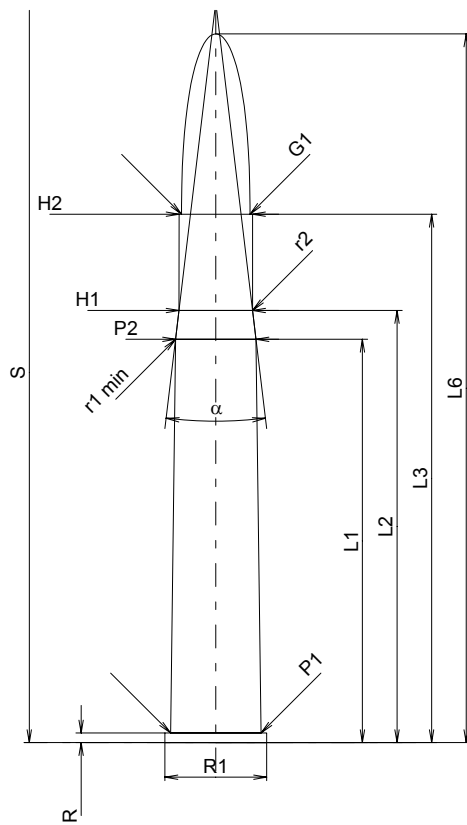
**CARTOUCHE MAXI****Longueurs**

L1 <sup>*</sup>	=	53.34
L2 <sup>*</sup>	=	57.15
L3 <sup>1)</sup>	=	69.88
L4	=	
L5	=	
L6	=	93.73

**Colot**

R <sup>1)</sup>	=	1.27	-0.25
R1	=	13.46	
R3	=		
E	=		
E1	=		
e min	=		
delta	=		
f	=		
beta	=		

**Chambre à poudre**

P1	=	11.96
P2 <sup>*</sup>	=	10.64

**Cône de raccordement**

alpha	=	13°37'13"
S	=	97.89
r1 min	=	8.13
r2	=	8.13

**Collet**

H1 <sup>*</sup>	=	9.73
H2 <sup>1)</sup>	=	9.70

**Projectile**

G1 <sup>1)</sup>	=	9.04
G2	=	
F	=	
L3+G <sup>1)</sup>	=	80.51

**Pressions (Énergies)****Méthode transducteur**

Pmax	=	3300 bar
PK	=	3795 bar
PE	=	4125 bar
M	=	25.00
EE	=	4900 Joule

**Autres indications**

Fe <sup>1)</sup>	=	0.15
delta L	=	

**CHAMBRE MINI****Longueurs**

L1 <sup>*</sup>	=	53.37
L2 <sup>*</sup>	=	57.18
L3 <sup>1)</sup>	=	70.13

**Cuvette**

R <sup>1)</sup>	=	1.30
R1	=	13.72
R2	=	
R3	=	
r	=	

**Chambre à poudre**

E	=	
P1 <sup>1)</sup>	=	11.99
P2 <sup>*</sup>	=	10.67

**Cône de raccordement**

alpha	=	13°46'08"
S	=	97.56
r1 max	=	
r2	=	

**Collet**

H1 <sup>*</sup>	=	9.75
H2 <sup>1)</sup>	=	9.73

**Prise de rayures**

G1 <sup>1)*</sup>	=	9.10
G <sup>1)*</sup>	=	10.63
alpha1	=	90°
h <sup>*</sup>	=	0.32
s	=	
i <sup>1)</sup>	=	1°15'
w	=	

**Canon**

F <sup>1)*</sup>	=	8.65
Z <sup>1)</sup>	=	9.00

**Rayures**

b	=	
N	=	
u	=	304.00
Q	=	58.77 mm <sup>2</sup>

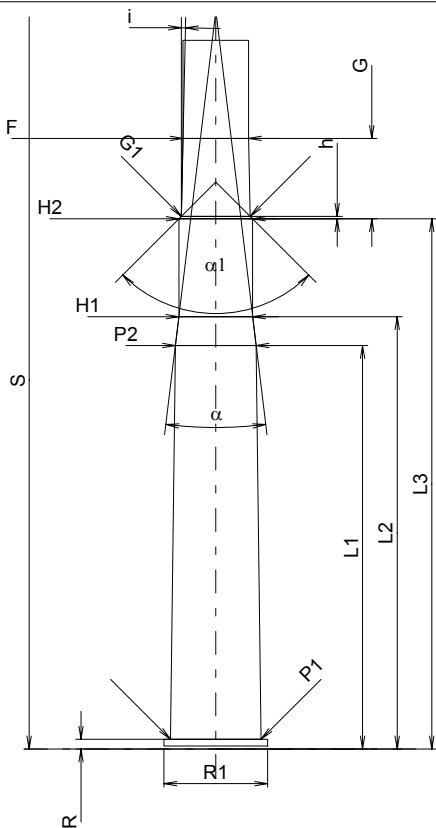

Échelle 1:1

Dimensions en << mm >>  
Dimensions et tolérances pour les canons  
d'épreuve: Voyez Annexe CR 1.

Notes: 1) A' contrôler pour la sécurité  
\* Dimensions de base