

C.I.P.**56/50 Spencer**

TAB. II

Date 04-05-18

Pays d'origine: US

Révision 04-09-27

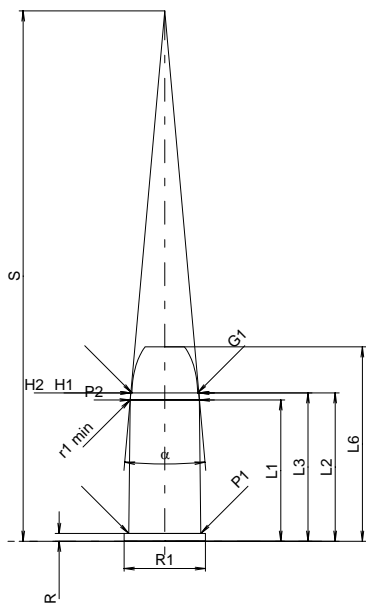
**CARTOUCHE MAXI****Longueurs**

L1	=	28.04
L2	=	29.44
L3 ¹⁾	=	29.44
L4	=	
L5	=	
L6	=	38.56

Culot

R ¹⁾	=	1.55	-0.25
R1	=	16.13	
R3	=		
E	=		
E1	=		
e min	=		
delta	=		
f	=		
beta	=		

Chambre à poudre

P1	=	14.30
P2 *	=	13.75

Cône de raccordement

alpha *	=	10°11'
S *	=	105.20
r1 min	=	0.50
r2	=	

Collet

H1 *	=	13.50
H2 ¹⁾	=	13.50

Projectile

G1 ¹⁾	=	13.00
G2	=	
F	=	
L1+G ¹⁾	=	39.76

Pressions (Énergies)**Méthode transducteur**

Pmax	=	2050 bar
PK	=	2358 bar
PE	=	2560 bar
M	=	17.50
EE	=	1950 Joule

Autres indications

Fe	=	0.15
delta L	=	

CHAMBRE MINI**Longueurs**

L1	=	
L2	=	
L3 ¹⁾	=	29.55

Cuvette

R	=	1.55
R1	=	16.20
R2	=	
R3	=	
r	=	

Chambre à poudre

E	=	
P1 ¹⁾	=	14.32
P2	=	

Cône de raccordement

alpha	=	
S	=	
r1 max	=	
r2	=	

Collet

H1	=	
H2 ¹⁾	=	13.77

Prise de rayures

G1 ¹⁾ *	=	13.03
G ¹⁾	=	10.32
alpha1 *	=	30°01'04"
h	=	1.38
s	=	9.70
i ¹⁾ *	=	15°
w	=	

Canon

F ¹⁾ *	=	12.70
Z ¹⁾	=	12.95

Rayures

b	=	3.50
N	=	6
u	=	508.00
Q	=	129.34 mm ²

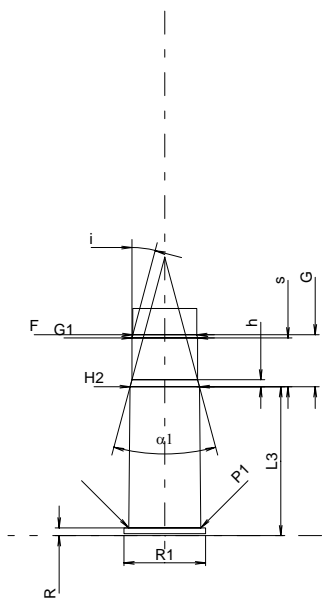

Échelle 1:1.5

Dimensions en << mm >>
Dimensions et tolérances pour les canons
d'épreuve: Voyez Annexe CR 1.

Notes: 1) A' contrôler pour la sécurité
* Dimensions de base