

**C.I.P.****50-95 Win.**

TAB. II

Date 09-05-05

Pays d'origine: US

Révision

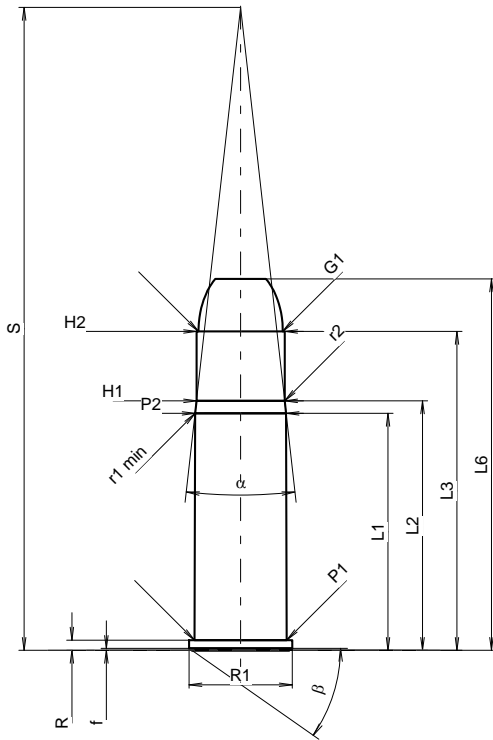
**CARTOUCHE MAXI****Longueurs**

L1	=	36.63
L2	=	38.55
L3 <sup>1)</sup>	=	49.28
L4	=	
L5	=	
L6	=	57.40

**Culot**

R <sup>1)</sup>	=	1.57	-0.25
R1	=	15.93	
R3	=		
E	=		
E1	=		
e min	=		
delta	=		
f	=	0.30	
beta	=	35°	

**Chambre à poudre**

P1	=	14.27
P2 *	=	14.05

**Cône de raccordement**

alpha *	=	12°46'43"
S *	=	99.36
r1 min	=	2.54
r2	=	2.54

**Collet**

H1 *	=	13.62
H2 <sup>1)</sup>	=	13.62

**Projectile**

G1 <sup>1)</sup>	=	13.03
G2	=	
F	=	
L3+G <sup>1)</sup>	=	51.39

**Pressions (Énergies)****Méthode transducteur**

Pmax	=	2100 bar
PK	=	2415 bar
PE	=	2625 bar
M	=	25.00
EE	=	5000 Joule

**Autres indications**

Fe <sup>1)4)</sup>	=	0.15
delta L	=	

**CHAMBRE MINI****Longueurs**

L1	=	36.53
L2	=	38.32
L3 <sup>1)</sup>	=	49.78

**Cuvette**

R <sup>1)</sup>	=	1.57
R1	=	15.98
R2	=	
R3	=	
r	=	

**Chambre à poudre**

E	=	
P1 <sup>1)</sup>	=	14.30
P2 *	=	14.08

**Cône de raccordement**

alpha *	=	12°45'02"
S *	=	99.54
r1 max	=	
r2	=	

**Collet**

H1 *	=	13.68
H2 <sup>1)</sup>	=	13.65

**Prise de rayures**

G1 <sup>1)</sup> *	=	13.65
G <sup>1)</sup>	=	2.11
alpha l	=	
h	=	
s	=	
i <sup>1)</sup> *	=	15°
w	=	

**Canon**

F <sup>1)</sup> *	=	12.52
Z <sup>1)</sup>	=	13.03

**Rayures**

b	=	3.75
N	=	6
u	=	508.00
Q	=	128.93 mm <sup>2</sup>

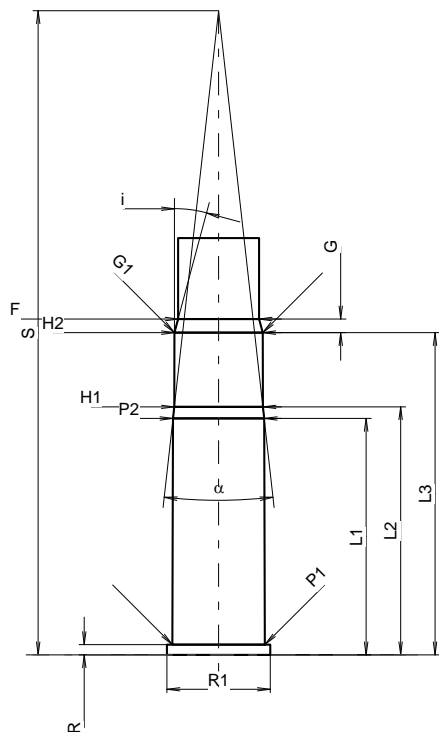

Échelle 1:1.17

Dimensions en << mm >>  
Dimensions et tolérances pour les canons  
d'épreuve: Voyez Annexe CR 1.

Notes: 1) A' contrôler pour la sécurité  
4) Feuillure sur la bourrelet  
\* Dimensions de base