

C.I.P.**350 No. 2 Rigby**

Country of Origin: GB

TAB. II

Date 84-06-14

Revision 02-05-15

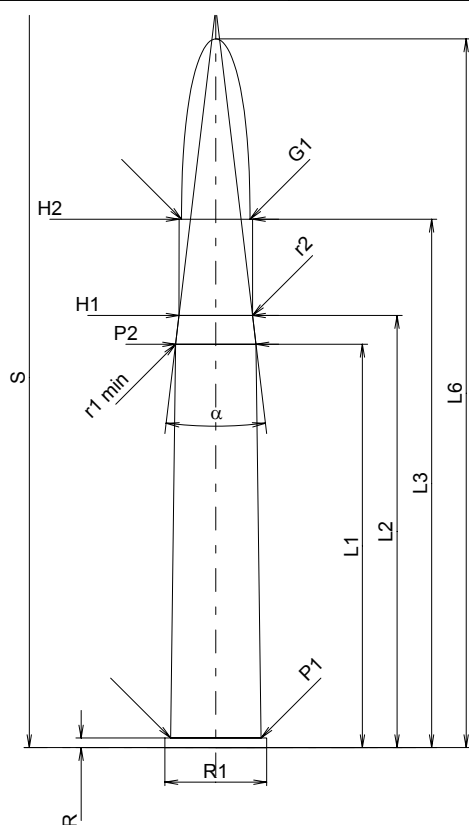
**CARTRIDGE MAXI****Lengths**

L1 [*]	=	53.34
L2 [*]	=	57.15
L3 ¹⁾	=	69.88
L4	=	
L5	=	
L6	=	93.73

Case Head

R ¹⁾	=	1.27	-0.25
R1	=	13.46	
R3	=		
E	=		
E1	=		
e min	=		
delta	=		
f	=		
beta	=		

Powder Chamber

P1	=	11.96
P2 [*]	=	10.64

Junction Cone

alpha	=	13°37'13"
S	=	97.89
r1 min	=	8.13
r2	=	8.13

Collar

H1 [*]	=	9.73
H2 ¹⁾	=	9.70

Projectile

G1 ¹⁾	=	9.04
G2	=	
F	=	
L3+G ¹⁾	=	80.51

Pressures (Energies)**Method Transducer**

Pmax	=	3300 bar
PK	=	3795 bar
PE	=	4125 bar
M	=	25.00
EE	=	4900 Joule

Miscellaneous Dimensions

Fe ¹⁾	=	0.15
delta L	=	

CHAMBER MINI**Lengths**

L1 [*]	=	53.37
L2 [*]	=	57.18
L3 ¹⁾	=	70.13

Breech

R ¹⁾	=	1.30
R1	=	13.72
R2	=	
R3	=	
r	=	

Powder Chamber

E	=	
P1 ¹⁾	=	11.99
P2 [*]	=	10.67

Junction Cone

alpha	=	13°46'08"
S	=	97.56
r1 max	=	
r2	=	

Collar

H1 [*]	=	9.75
H2 ¹⁾	=	9.73

Commencement of Rifling

G1 ¹⁾ *	=	9.10
G ¹⁾ *	=	10.63
alpha1	=	90°
h [*]	=	0.32
s	=	
i ¹⁾	=	1°15'
w	=	

Barrel

F ¹⁾ *	=	8.65
Z ¹⁾	=	9.00

Grooves

b	=	
N	=	
u	=	304.00
Q	=	58.77 mm ²

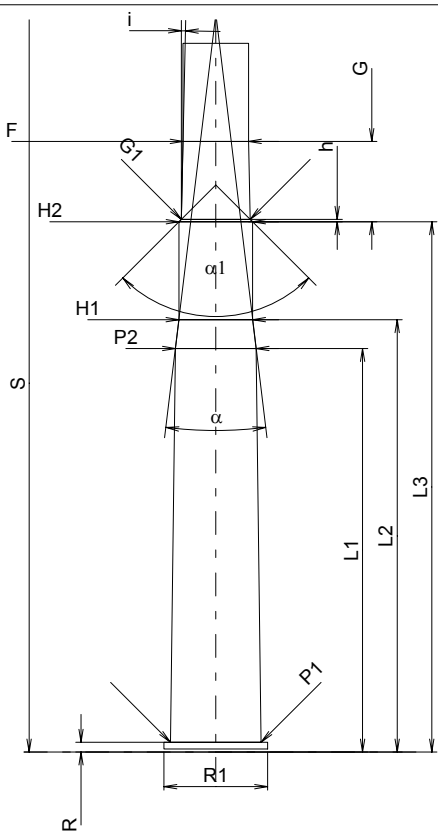

Scale 1:1

Dimensions in << mm >>
Dimensions and Tolerances for Proof Barrels
see Appendix CR 1.

Notes: 1) Check for safety reasons
* Basic dimensions