

C.I.P.

7mm Mag. FI. H&H

Country of Origin: GB

TAB. II

Date 84-06-14

Revision 02-05-15

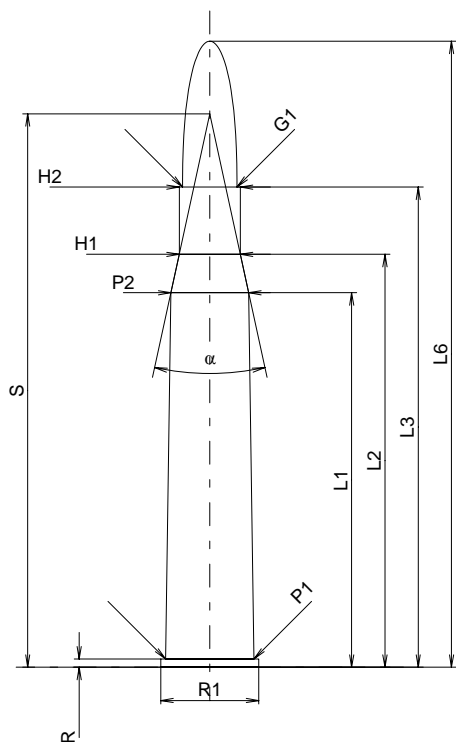
**CARTRIDGE MAXI****Lengths**

L1 *	=	49.53
L2 *	=	54.61
L3 ¹⁾	=	63.50
L4	=	
L5	=	
L6	=	82.80

Case Head

R ¹⁾	=	1.09	-0.25
R1	=	12.95	
R3	=		
E	=		
E1	=		
e min	=		
delta	=		
f	=		
beta	=		

Powder Chamber

P1	=	11.68
P2 *	=	10.29

Junction Cone

alpha	=	24°31'59"
S	=	73.19
r1 min	=	
r2	=	

Collar

H1 *	=	8.08
H2 ¹⁾	=	8.08

Projectile

G1 ¹⁾	=	7.21
G2	=	
F	=	
L3+G ¹⁾	=	69.04

Pressures (Energies)**Method Transducer**

Pmax	=	3300 bar
PK	=	3795 bar
PE	=	4125 bar
M	=	25.00
EE	=	3150 Joule

Miscellaneous Dimensions

Fe ¹⁾	=	0.15
delta L	=	

CHAMBER MINI**Lengths**

L1 *	=	49.56
L2 *	=	54.64
L3 ¹⁾	=	63.75

Breech

R ¹⁾	=	1.12
R1	=	13.21
R2	=	
R3	=	
r	=	

Powder Chamber

E	=	
P1 ¹⁾	=	11.71
P2 *	=	10.31

Junction Cone

alpha	=	24°31'58"
S	=	73.27
r1 max	=	0.50
r2	=	0.50

Collar

H1 *	=	8.10
H2 ¹⁾	=	8.10

Commencement of Rifling

G1 ¹⁾ *	=	7.25
G ¹⁾ *	=	5.54
alpha1	=	180°
h	=	
s	=	
i ¹⁾	=	1°29'57"
w	=	

Barrel

F ¹⁾ *	=	6.96
Z ¹⁾	=	7.20

Grooves

b	=	
N	=	
u	=	220.00
Q	=	38.05 mm ²

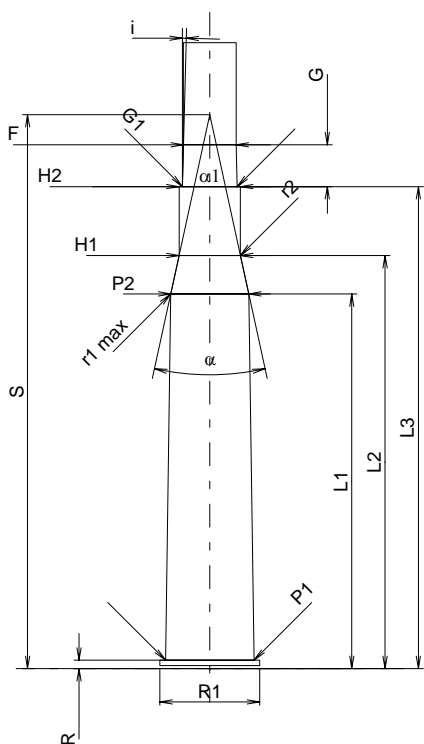

Scale 1:1

Dimensions in << mm >>
Dimensions and Tolerances for Proof Barrels
see Appendix CR 1.

Notes: 1) Check for safety reasons
* Basic dimensions