

**C.I.P.****8 x 75 RS**

TAB. II

Datum 84-06-14

Revision 02-05-15

Ursprungsland: DE

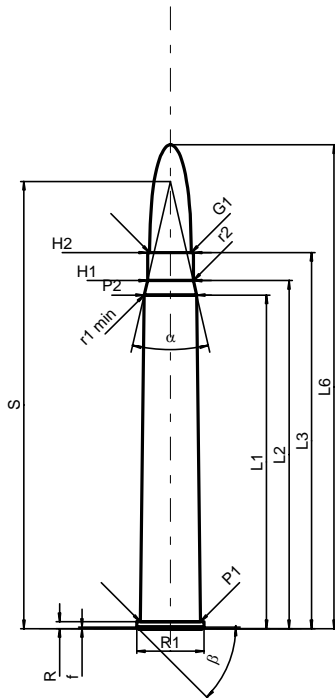
**PATRONE MAXI****Längen**

L1 *	=	66.20
L2 *	=	69.06
L3 <sup>1)</sup>	=	74.60
L4	=	
L5	=	
L6	=	96.00

**Hülsenboden**

R <sup>1)</sup>	=	1.40	-0.25
R1	=	13.35	
R3	=		
E	=		
E1	=		
e min	=		
delta	=		
f	=	0.30	
beta	=	45°	

**Pulverkammer**

P1	=	11.90
P2 *	=	10.40

**Schulterkonus**

alpha	=	26°
S	=	88.72
r1 min	=	0.50
r2	=	0.50

**Hülsenhals**

H1 *	=	9.08
H2 <sup>1)</sup>	=	9.08

**Geschoss**

G1 <sup>1)</sup>	=	8.22
G2	=	
F	=	
L3+G <sup>1)</sup>	=	108.60

**Drücke (Energien)****Mech. elektr. Wandler**

Pmax	=	3800 bar
PK	=	4370 bar
PE	=	4750 bar
M	=	25.00
EE	=	4790 Joule

**Verschiedene Daten**

Fe <sup>1)</sup>	=	0.15
delta L	=	

**PATRONENLAGER MINI****Längen**

L1 *	=	66.20
L2 *	=	69.06
L3 <sup>1)</sup>	=	75.00

**Stoßboden**

R <sup>1)</sup>	=	1.40
R1	=	13.40
R2	=	
R3	=	
r	=	

**Pulverkammer**

E	=	
P1 <sup>1)</sup>	=	11.93
P2 *	=	10.43

**Schulterkonus**

alpha	=	26°
S	=	88.79
r1 max	=	0.50
r2	=	0.50

**Hülsenhals**

H1 *	=	9.11
H2 <sup>1)</sup>	=	9.10

**Geschossübergang**

G1 <sup>1)</sup> *	=	8.23
G <sup>1)</sup> *	=	34.00
alpha1	=	180°
h	=	
s	=	
i <sup>1)</sup>	=	0°17'11"
w	=	

**Lauf**

F <sup>1)</sup> *	=	7.89
Z <sup>1)</sup>	=	8.20

**Züge**

b	=	4.40
N	=	4
u	=	240.00
Q	=	51.78 mm <sup>2</sup>

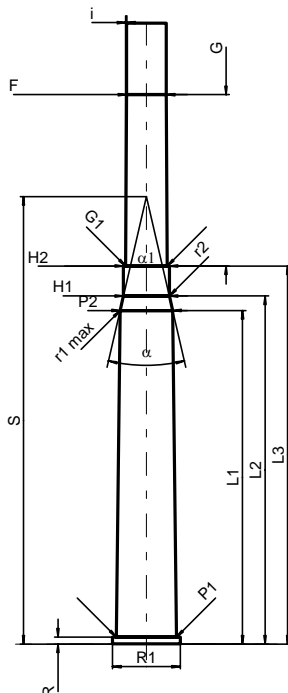

Maßstab 1:1.5

Maße in << mm >>  
Maße und Toleranzen für Messläufe  
siehe Anhang CR 1.

Bemerkungen: 1) Kontrolle aus Sicherheitsgründen  
\* Grundmaße