

C.I.P.**45-70 Govt.**

TAB. II

Datum 84-06-14

Revision 02-05-15

Ursprungsland: US

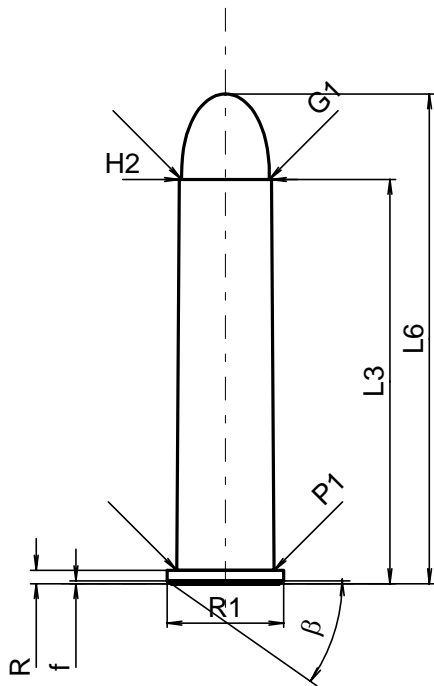
**PATRONE MAXI****Längen**

L1	=	
L2	=	
L3 ¹⁾	=	53.47
L4	=	
L5	=	
L6	=	64.77

Hülsenboden

R ¹⁾	=	1.78	-0.25
R1	=	15.44	
R3	=		
E	=		
E1	=		
e min	=		
delta	=		
f	=	0.38	
beta	=	35°	

Pulverkammer

P1	=	12.84
P2	=	

Schulterkonus

alpha	=	
S	=	
r1 min	=	
r2	=	

Hülsenhals

H1	=	
H2 ¹⁾	=	12.19

Geschoss

G1 ¹⁾	=	11.63
G2	=	
F	=	
L3+G ¹⁾	=	55.22

Drücke (Energien)**Mech. elektr. Wandler**

Pmax	=	2200 bar
PK	=	2530 bar
PE	=	2750 bar
M	=	25.00
EE	=	3414 Joule

Verschiedene Daten

Fe ¹⁾	=	0.15
delta L	=	

PATRONENLAGER MINI**Längen**

L1	=	
L2	=	
L3 ¹⁾	=	53.59

Stoßboden

R ¹⁾	=	1.78
R1	=	15.70
R2	=	
R3	=	
r	=	

Pulverkammer

E	=	
P1 ¹⁾	=	12.91
P2	=	

Schulterkonus

alpha	=	
S	=	
r1 max	=	
r2	=	

Hülsenhals

H1	=	
H2 ¹⁾	=	12.22

Geschossübergang

G1 ^{1)*}	=	12.22
G ¹⁾	=	1.75
alpha1	=	
h	=	
s	=	
i ^{1)*}	=	12°45'
w	=	

Lauf

F ^{1)*}	=	11.43
Z ¹⁾	=	11.58

Züge

b	=	3.58
N	=	6
u	=	508.00
Q	=	104.25 mm ²

Maßstab 1:1

Maße in << mm >>
Maße und Toleranzen für Messläufe
siehe Anhang CR 1.

Bemerkungen: 1) Kontrolle aus Sicherheitsgründen
* Grundmaße