

**C.I.P.****8 x 57 IR**

TAB.

II

Date

84-06-14

Révision

16-05-18

Pays d'origine: DE

Marquage alternatif: 8 x 57 JR

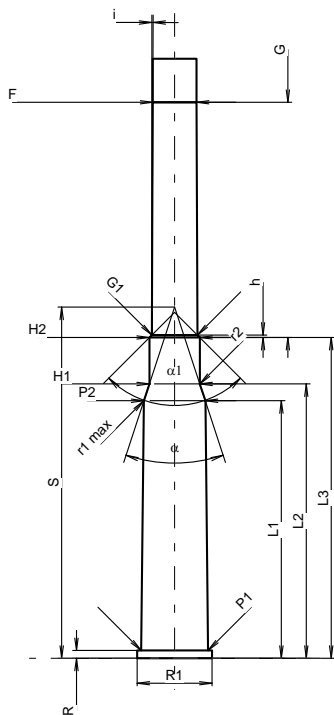
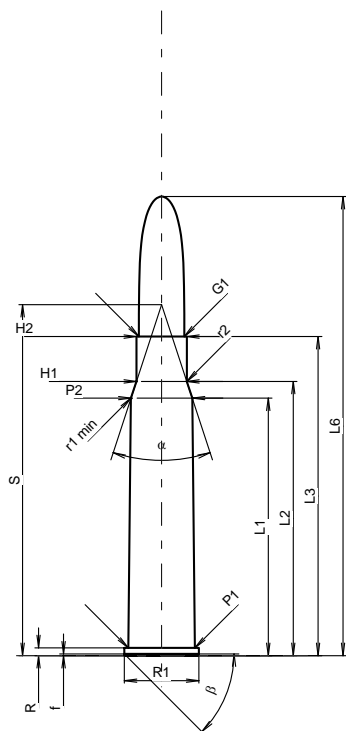

Échelle 1:1.35

Dimensions en << mm >>  
Dimensions et tolérances pour les canons  
d'épreuve: Voyez Annexe CR 1.

**CARTOUCHE MAXI****Longueurs**

L1 *	=	46.00
L2 *	=	48.99
L3 <sup>1)</sup>	=	57.00
L4	=	
L5	=	
L6	=	82.00

**Culot**

R <sup>1)</sup>	=	1.40	-0.25
R1	=	13.32	
R3	=		
E	=		
E1	=		
e min	=		
delta	=		
f	=	0.30	
beta	=	45°	

**Chambre à poudre**

P1	=	11.92
P2 *	=	10.95

**Cône de raccordement**

alpha	=	36°17'39"
S	=	62.70
r1 min	=	0.50
r2	=	0.50

**Collet**

H1 *	=	8.99
H2 <sup>1)</sup>	=	8.99

**Projectile**

G1 <sup>1)</sup>	=	8.09
G2	=	
F	=	
L3+G <sup>1)</sup>	=	99.00

**Pressions (Énergies)****Méthode transducteur**

Pmax	=	3200 bar
PK	=	3680 bar
PE	=	4000 bar
M	=	25.00
EE	=	3315 Joule

**Autres indications**

Fe <sup>1)4)</sup>	=	0.15
delta L	=	

**CHAMBRE MINI****Longueurs**

L1 *	=	46.00
L2 *	=	49.00
L3 <sup>1)</sup>	=	57.30

**Cuvette**

R <sup>1)</sup>	=	1.40
R1	=	13.37
R2	=	
R3	=	
r	=	

**Chambre à poudre**

E	=	
P1 <sup>1)</sup>	=	11.95
P2 *	=	10.98

**Cône de raccordement**

alpha	=	36°21'12"
S	=	62.72
r1 max	=	0.50
r2	=	0.50

**Collet**

H1 *	=	9.01
H2 <sup>1)</sup>	=	9.00

**Prise de rayures**

G1 <sup>1)</sup> *	=	8.15
G <sup>1)</sup> *	=	42.00
alpha1	=	90°
h *	=	0.43
s	=	
i <sup>1)</sup>	=	0°14'28"
w	=	

**Canon**

F <sup>1)</sup> *	=	7.80
Z <sup>1)</sup>	=	8.07

**Rayures**

b	=	4.40
N	=	4
u	=	240.00
Q	=	50.30 mm <sup>2</sup>

Notes: 1) A' contrôler pour la sécurité  
4) Feuillure sur la bourrelet  
\* Dimensions de base