

C.I.P.**50-90 Sharps 2" 1/2**

TAB. II

Date 17-05-17

Country of Origin: US

Revision

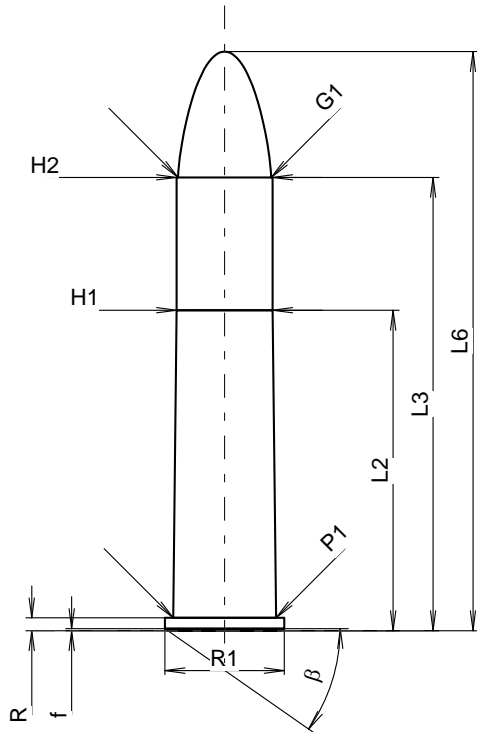
**CARTRIDGE MAXI****Lengths**

L1	=	
L2	=	44.98
L3 ¹⁾	=	63.63
L4	=	
L5	=	
L6	=	81.28

Case Head

R ¹⁾	=	1.80	-0.25
R1	=	16.76	
R3	=		
E	=		
E1	=		
e min	=		
δ	=		
f	=	0.30	
β	=	35°	

Powder Chamber

P1	=	14.43
P2	=	

Junction Cone

α	=	
S	=	
r1 min	=	
r2	=	

Collar

H1	=	13.49
H2 ¹⁾	=	13.49

Projectile

G1 ¹⁾	=	13.08
G2	=	
F	=	
L3+G ¹⁾	=	65.53

Pressures (Energies)**Method Transducer**

Pmax	=	2100 bar
PK	=	2415 bar
PE	=	2625 bar
M	=	25.00
EE	=	5000 Joule

Miscellaneous Dimensions

Fe ¹⁾⁴⁾	=	0.15
delta L	=	

CHAMBER MINI**Lengths**

L1	=	
L2	=	45.00
L3 ¹⁾	=	63.98

Breech

R ¹⁾	=	1.80
R1	=	16.81
R2	=	
R3	=	
r	=	

Powder Chamber

E	=	
P1 ¹⁾	=	14.46
P2	=	

Junction Cone

α	=	
S	=	
r1 max	=	
r2	=	

Collar

H1	=	13.70
H2 ¹⁾	=	13.70

Commencement of Rifling

G1 ¹⁾ *	=	13.54
G ¹⁾	=	1.90
α1	=	
h	=	
s	=	
i ¹⁾ *	=	15°01'31"
w	=	

Barrel

F ¹⁾ *	=	12.52
Z ¹⁾	=	13.03

Grooves

b	=	3.75
N	=	6
u	=	508.00
Q	=	128.93 mm ²

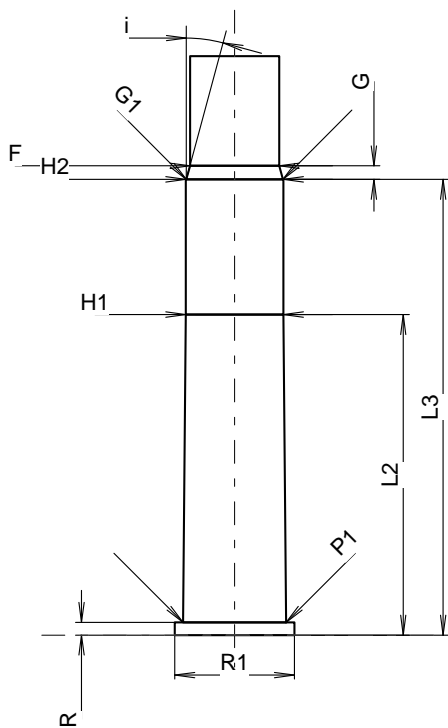

Scale 1:1.06

Dimensions in << mm >>
Dimensions and Tolerances for Proof Barrels
see Appendix CR 1.

Notes: 1) Check for safety reasons
4) Headspace on Rim
* Basic dimensions