

C.I.P.**351 Win. SL**

Country of Origin: US

TAB. II

Date 84-06-14

Revision 11-05-25

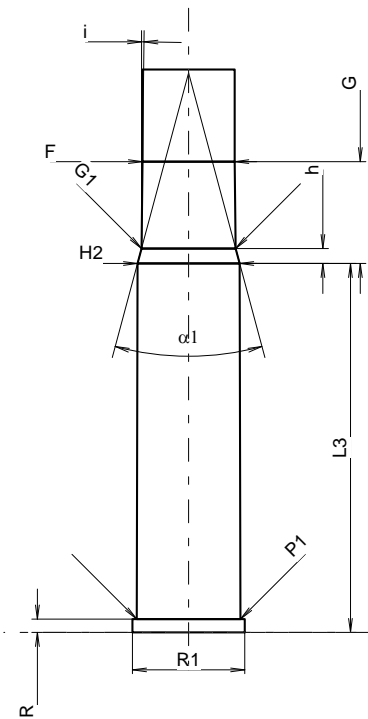
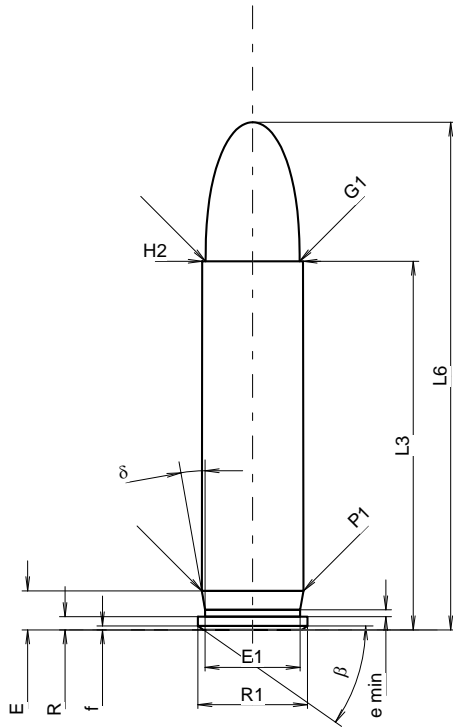

Scale 1.39:1

CARTRIDGE MAXI**Lengths**

L1	=	
L2	=	
L3 ¹⁾	=	35.05
L4	=	
L5	=	
L6	=	48.26

Case Head

R ¹⁾	=	1.27	-0.25
R1	=	10.41	
R3	=		
E	=	3.72	
E1	=	9.02	
e min	=	0.64	
δ	=	10°	
f	=	0.38	
β	=	35°	

Powder Chamber

P1	=	9.66
P2	=	

Junction Cone

α	=	
S	=	
r1 min	=	
r2	=	

Collar

H1	=	
H2 ¹⁾	=	9.58

Projectile

G1 ¹⁾	=	8.94
G2	=	
F	=	
L3+G ¹⁾	=	44.73

Pressures (Energies)**Method Transducer**

Pmax	=	3650 bar
PK	=	4198 bar
PE	=	4560 bar
M	=	17.50
EE	=	1330 Joule

Miscellaneous Dimensions

Fe ¹⁾⁴⁾	=	0.15
delta L	=	

CHAMBER MINI**Lengths**

L1	=	
L2	=	
L3 ¹⁾	=	35.07

Breech

R ¹⁾	=	1.27
R1	=	10.67
R2	=	
R3	=	
r	=	

Powder Chamber

E	=	
P1 ¹⁾	=	9.86
P2	=	

Junction Cone

α	=	
S	=	
r1 max	=	
r2	=	

Collar

H1	=	
H2 ¹⁾	=	9.71

Commencement of Rifling

G1 ¹⁾ *	=	8.95
G ¹⁾	=	9.68
α_1	=	30°
h	=	1.42
s	=	
i ¹⁾ *	=	0°39'31"
w	=	

Barrel

F ¹⁾ *	=	8.76
Z ¹⁾	=	8.92

Grooves

b	=	2.75
N	=	6
u	=	406.00
Q	=	61.61 mm ²

Dimensions in << mm >>
Dimensions and Tolerances for Proof Barrels
see Appendix CR 1.

Notes: 1) Check for safety reasons
4) Headspace on Rim
* Basic dimensions