

**C.I.P.****225 Win.**

TAB.

II

Date

84-06-14

Révision

11-05-25

Pays d'origine: US

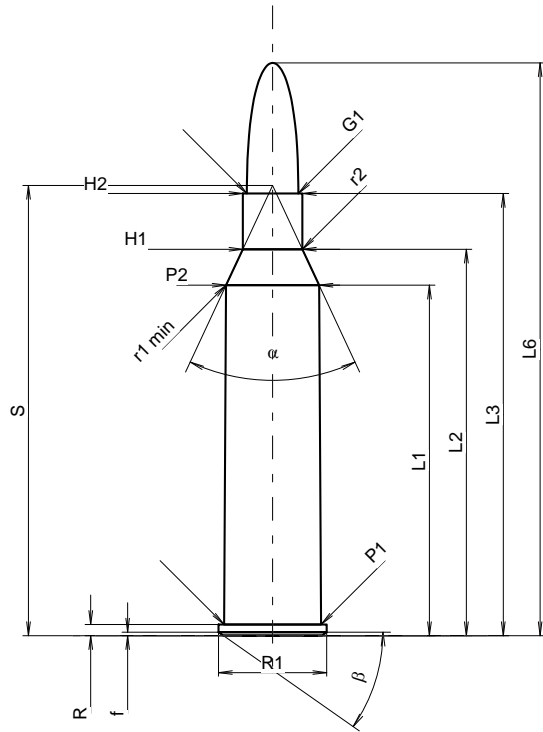
**CARTOUCHE MAXI****Longueurs**

L1	=	38.86
L2	=	42.84
L3 <sup>1)</sup>	=	49.02
L4	=	
L5	=	
L6	=	63.50

**Culot**

R <sup>1)</sup>	=	1.24	-0.25
R1	=	12.01	
R3	=		
E	=		
E1	=		
e min	=		
delta	=		
f	=	0.38	
beta	=	35°	

**Chambre à poudre**

P1	=	10.77
P2 *	=	10.31

**Cône de raccordement**

alpha *	=	50°
S *	=	49.92
r1 min	=	0.76
r2	=	2.54

**Collet**

H1 *	=	6.60
H2 <sup>1)</sup>	=	6.60

**Projectile**

G1 <sup>1)</sup>	=	5.70
G2	=	
F	=	
L3+G <sup>1)</sup>	=	53.23

**Pressions (Énergies)****Méthode transducteur**

Pmax	=	3900 bar
PK	=	4485 bar
PE	=	4875 bar
M	=	25.00
EE	=	2195 Joule

**Autres indications**

Fe <sup>1)3)</sup>	=	0.10
delta L	=	0.10

**CHAMBRE MINI****Longueurs**

L1	=	38.72
L2	=	42.69
L3 <sup>1)</sup>	=	49.28

**Cuvette**

R <sup>1)</sup>	=	1.35
R1	=	12.27
R2	=	
R3	=	
r	=	0.80

**Chambre à poudre**

E	=	
P1 <sup>1)</sup>	=	10.80
P2 *	=	10.35

**Cône de raccordement**

alpha *	=	50°
S *	=	49.82
r1 max	=	0.76
r2	=	2.54

**Collet**

H1 *	=	6.65
H2 <sup>1)</sup>	=	6.63

**Prise de rayures**

G1 <sup>1)</sup> *	=	5.74
G <sup>1)</sup>	=	4.21
alpha1 *	=	60°
h	=	0.77
s	=	
i <sup>1)</sup> *	=	1°30'
w	=	

**Canon**

F <sup>1)</sup> *	=	5.56
Z <sup>1)</sup>	=	5.68

**Rayures**

b	=	1.88
N	=	6
u	=	356.00
Q	=	24.97 mm <sup>2</sup>

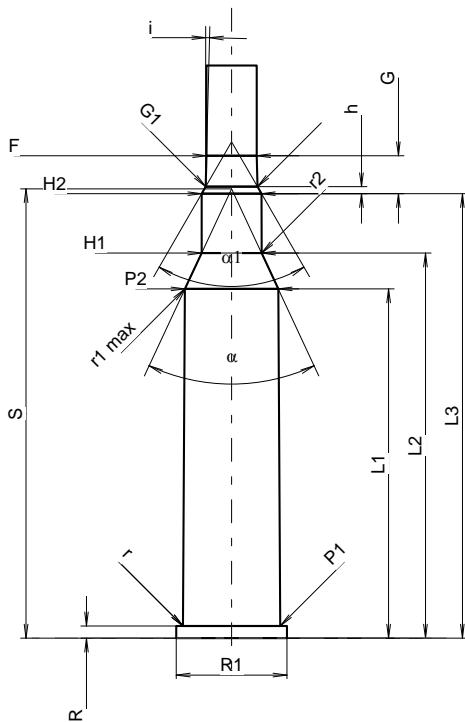

Échelle 1.19:1

Dimensions en << mm >>  
Dimensions et tolérances pour les canons  
d'épreuve: Voyez Annexe CR 1.

Notes: 1) A' contrôler pour la sécurité  
3) Feuillure sur la cone de raccordement  
\* Dimensions de base