

C.I.P.**250 Savage**

Pays d'origine: US

TAB. I

Date 84-06-14

Révision 02-05-15

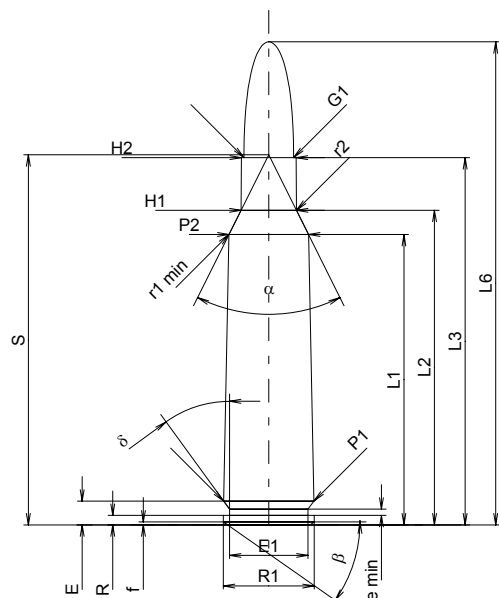
**CARTOUCHE MAXI****Longueurs**

L1 ¹⁾	=	38.40	-0.20
L2 ¹⁾	=	41.60	-0.20
L3 ¹⁾	=	48.56	
L4	=		
L5	=		
L6	=	63.88	

Culot

R	=	1.24	
R1	=	12.01	
R3	=		
E	=	3.14	
E1	=	10.39	
e min	=	0.84	
delta	=	36°	
f	=	0.38	
beta	=	35°	

Chambre à poudre

P1	=	11.93	
P2 ^{1)*}	=	10.52	-0.20

Cône de raccordement

alpha*	=	53°	
S*	=	48.95	
r1 min	=	2.54	
r2	=	2.54	

Collet

H1*	=	7.33	
H2 ¹⁾	=	7.25	

Projectile

G1 ¹⁾	=	6.55	
G2	=		
F	=		
L3+G ¹⁾	=	51.55	

Pressions (Énergies)**Méthode transducteur**

Pmax	=	3650 bar	
PK	=	4198 bar	
PE	=	4560 bar	
M	=	25.00	
EE	=	2900 Joule	

Autres indications

Fe ¹⁾	=	0.15	
delta L	=		

CHAMBRE MINI**Longueurs**

L1	=	38.36	
L2	=	41.58	
L3 ¹⁾	=	48.82	

Cuvette

R	=		
R1	=	12.14	
R2	=		
R3	=		
r	=		

Chambre à poudre

E	=	3.14	
P1 ¹⁾	=	12.01	
P2*	=	10.56	

Cône de raccordement

alpha ^{1)*}	=	53°	
S*	=	48.95	
r1 max	=	2.54	
r2	=	2.54	

Collet

H1*	=	7.35	
H2 ¹⁾	=	7.26	

Prise de rayures

G1 ^{1)*}	=	6.63	
G ¹⁾	=	2.99	
alpha1*	=	90°	
h	=	0.32	
s	=		
i ^{1)*}	=	3°	
w	=		

Canon

F ^{1)*}	=	6.35	
Z ¹⁾	=	6.53	

Rayures

b	=	2.24	
N	=	6	
u	=	356.00	
Q	=	32.90	mm ²

Échelle 1:1

Dimensions en << mm >>
Dimensions et tolérances pour les canons
d'épreuve: Voyez Annexe CR 1.

Notes: 1) A' contrôler pour la sécurité
* Dimensions de base