

C.I.P.**416 Rigby**

TAB. I

Date 84-06-14

Pays d'origine: GB

Révision 02-05-15

CARTOUCHE MAXI**CHAMBRE MINI****Longueurs**

L1 ^{1)*}	=	59.77	-0.20
L2 ^{1)*}	=	60.96	-0.20
L3 ¹⁾	=	73.66	
L4	=		
L5	=		
L6	=	95.25	

Longueurs

L1 [*]	=	59.72
L2 [*]	=	60.91
L3 ¹⁾	=	73.96

Culot

R	=	1.65
R1	=	14.99
R3	=	
E	=	3.81
E1	=	12.70
e min	=	0.81
δ	=	39°55'48"
f	=	
β	=	

Cuvette

R	=	1.65
R1	=	15.04
R2	=	
R3	=	
r	=	

Chambre à poudre

P1	=	14.96
P2 ^{1)*}	=	13.72

Chambre à poudre

E	=	3.81
P1 ¹⁾	=	14.99
P2 [*]	=	13.74

Cône de raccordement

α	=	89°45'32"
S	=	66.66
r1 min	=	
r2	=	

Cône de raccordement

α ¹⁾	=	89°30'57"
S	=	66.65
r1 max	=	
r2	=	

Collet

H1 [*]	=	11.35
H2 ¹⁾	=	11.33

Collet

H1 [*]	=	11.38
H2 ¹⁾	=	11.35

Projectile

G1 ¹⁾	=	10.57
G2	=	
F	=	
L3+G ¹⁾	=	81.28

Prise de rayures

G1 ^{1)*}	=	10.59
G ^{1)*}	=	7.62
α1	=	90°
h [*]	=	0.38
s	=	
i ¹⁾	=	0°54'36"
w	=	

Pressions (Énergies)**Méthode transducteur**

Pmax	=	3250 bar
PK	=	3738 bar
PE	=	4060 bar
M	=	25.00
EE	=	7270 Joule

Canon

F ^{1)*}	=	10.36
Z ¹⁾	=	10.57

Rayures

b	=	3.60
N	=	6
u	=	420.00
Q	=	86.61 mm ²

Autres indications

Fe ¹⁾	=	0.15
delta L	=	

Notes: 1) A' contrôler pour la sécurité
* Dimensions de base

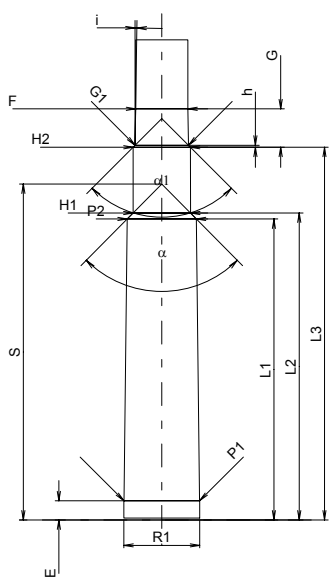
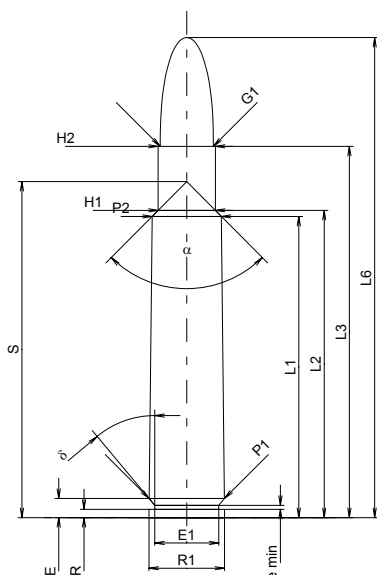

Échelle 1:1.5

Dimensions en << mm >>
Dimensions et tolérances pour les canons
d'épreuve: Voyez Annexe CR 1.