

C.I.P.

7 mm Rem. SA Ultra Mag.

Country of Origin: US

TAB. I

Date 02-03-01

Revision 04-09-27

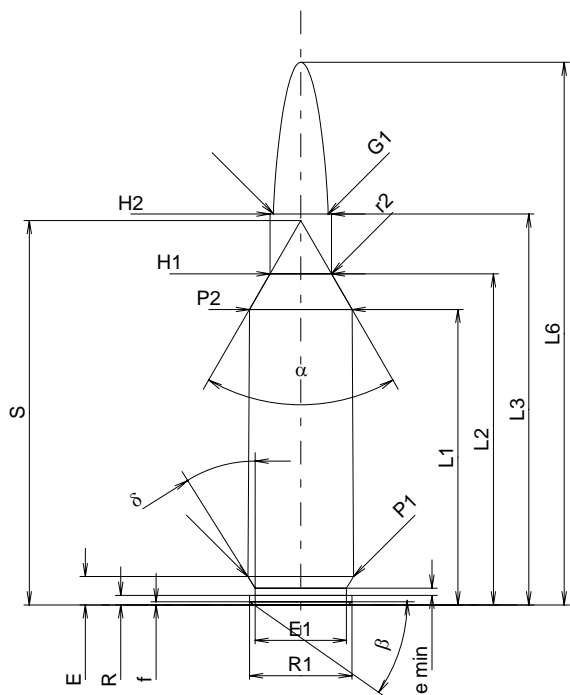

CARTRIDGE MAXI

Lengths

L1 ¹⁾	=	39.07	-0.20
L2 ¹⁾	=	43.79	-0.20
L3 ¹⁾	=	51.69	
L4	=		
L5	=		
L6	=	71.76	

Case Head

R	=	1.27	
R1	=	13.56	
R3	=		
E	=	3.75	
E1	=	12.07	
e min	=	0.94	
delta	=	32°	
f	=	0.41	
beta	=	35°	

Powder Chamber

P1	=	14.00	
P2 ^{1)*}	=	13.58	-0.20

Junction Cone

alpha*	=	60°	
S*	=	50.83	
r1 min	=		
r2	=	3.18	

Collar

H1*	=	8.13	
H2 ¹⁾	=	8.13	

Projectile

G1 ¹⁾	=	7.23	
G2	=	7.04	
F	=		
L3+G ¹⁾	=	59.88	

Pressures (Energies)

Method Transducer

Pmax	=	4400 bar	
PK	=	5060 bar	
PE	=	5500 bar	
M	=	25.00	
EE	=	4500 Joule	

Miscellaneous Dimensions

Fe	=	0.10	
delta L	=		

CHAMBER MINI

Lengths

L1	=	38.95	
L2	=	43.65	
L3 ¹⁾	=	51.94	

Breech

R	=		
R1	=	14.05	
R2	=		
R3	=		
r	=		

Powder Chamber

E	=	3.75	
P1 ¹⁾	=	14.01	
P2*	=	13.61	

Junction Cone

alpha ^{1)*}	=	60°	
S*	=	50.74	
r1 max	=		
r2	=	3.18	

Collar

H1*	=	8.18	
H2 ¹⁾	=	8.15	

Commencement of Rifling

G1 ^{1)*}	=	7.23	
G ¹⁾	=	8.19	
alpha1*	=	90°	
h	=	0.46	
s	=	2.75	
i ^{1)*}	=	1°	
w	=		

Barrel

F ^{1)*}	=	7.04	
Z ¹⁾	=	7.21	

Grooves

b	=	2.79	
N	=	6	
u	=	254.00	
Q	=	40.39	mm ²

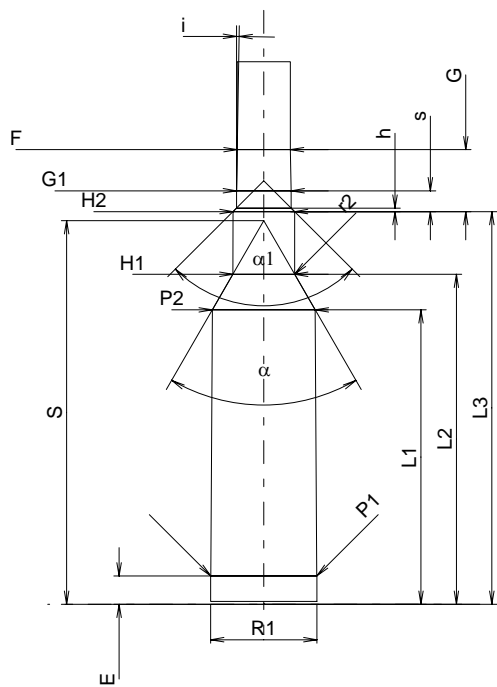

Scale 1:1

Dimensions in << mm >>
Dimensions and Tolerances for Proof Barrels
see Appendix CR 1.

Notes: 1) Check for safety reasons
* Basic dimensions