

**C.I.P.****45 Blaser**

Country of Origin: DE

TAB. I

Date 04-09-27

Revision 05-12-07

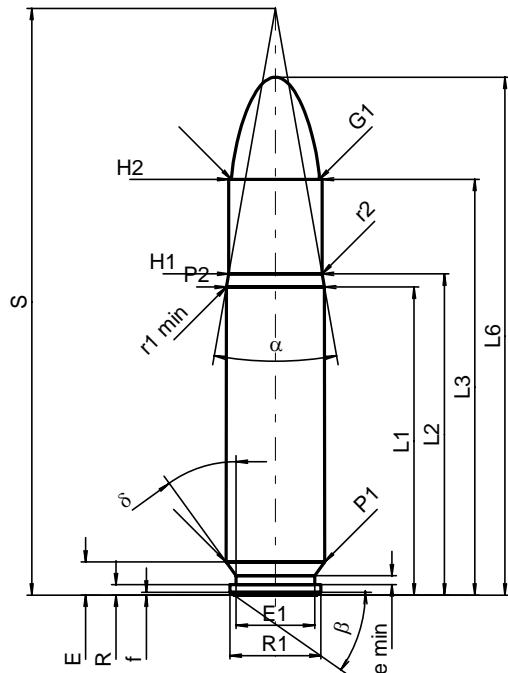
**CARTRIDGE MAXI****Lengths**

L1 <sup>1)*</sup>	=	40.74	-0.20
L2 <sup>1)*</sup>	=	42.50	-0.20
L3 <sup>1)</sup>	=	55.00	
L4	=		
L5	=		
L6	=	68.50	

**Case Head**

R	=	1.37	
R1	=	12.01	
R3	=		
E	=	4.39	
E1	=	10.39	
e min	=	1.20	
delta	=	36°	
f	=	0.38	
beta	=	35°	

**Powder Chamber**

P1	=	13.03	
P2 <sup>1)*</sup>	=	12.98	-0.20

**Junction Cone**

alpha	=	19°58'44"	
S	=	77.59	
r1 min	=	0.50	
r2	=	0.50	

**Collar**

H1*	=	12.36	
H2 <sup>1)</sup>	=	12.36	

**Projectile**

G1 <sup>1)</sup>	=	11.64	
G2	=		
F	=		
L3+G <sup>1)</sup>	=	59.19	

**Pressures (Energies)****Method Transducer**

Pmax	=	3700 bar	
PK	=	4255 bar	
PE	=	4625 bar	
M	=	25.00	
EE	=	4650 Joule	

**Miscellaneous Dimensions**

Fe	=	0.15	
delta L	=		

**CHAMBER MINI****Lengths**

L1*	=	40.66	
L2*	=	42.42	
L3 <sup>1)</sup>	=	55.25	

**Breech**

R	=		
R1	=	12.03	
R2	=		
R3	=		
r	=		

**Powder Chamber**

E	=	4.41	
P1 <sup>1)</sup>	=	13.08	
P2*	=	13.02	

**Junction Cone**

alpha <sup>1)</sup>	=	19°58'44"	
S	=	77.62	
r1 max	=	0.50	
r2	=	0.50	

**Collar**

H1*	=	12.40	
H2 <sup>1)</sup>	=	12.38	

**Commencement of Rifling**

G1 <sup>1)*</sup>	=	11.66	
G <sup>1)*</sup>	=	4.19	
alpha1	=	90°	
h	=	0.36	
s*	=	2.00	
i <sup>1)</sup>	=	3°00'21"	
w	=		

**Barrel**

F <sup>1)*</sup>	=	11.43	
Z <sup>1)</sup>	=	11.63	

**Grooves**

b	=	3.81	
N	=	6	
u	=	356.00	
Q	=	104.94	mm <sup>2</sup>

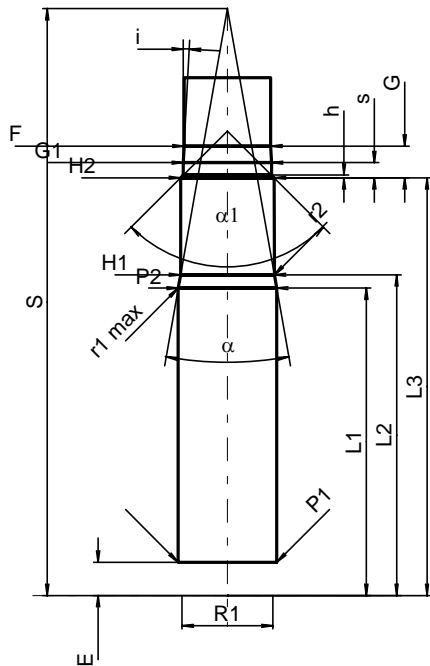

Scale 1:1

Dimensions in << mm >>  
 Dimensions and Tolerances for Proof Barrels  
 see Appendix CR 1.

Notes: 1) Check for safety reasons  
 \* Basic dimensions