

C.I.P.**404 Riml. N.E.**

TAB. I

Date 84-06-14

Revision 05-05-25

Country of Origin: GB

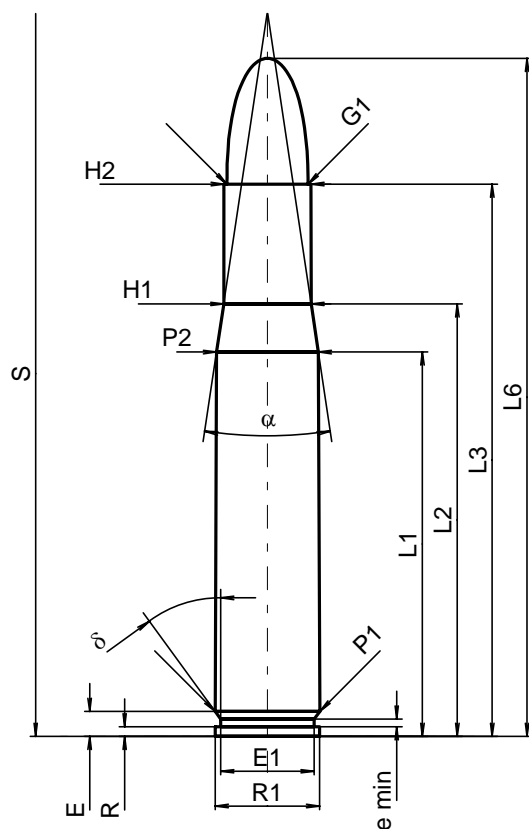
**CARTRIDGE MAXI****Lengths**

L1 ^{1)*}	=	50.82	-0.20
L2 ^{1)*}	=	57.18	-0.20
L3 ¹⁾	=	73.02	
L4	=		
L5	=		
L6	=	89.66	

Case Head

R	=	1.27	
R1	=	13.79	
R3	=		
E	=	3.30	
E1	=	12.37	
e min	=	1.02	
delta	=	36°02'39"	
f	=		
beta	=		

Powder Chamber

P1	=	13.84	
P2 ^{1)*}	=	13.46	-0.20

Junction Cone

alpha	=	16°59'27"	
S	=	95.88	
r1 min	=		
r2	=		

Collar

H1*	=	11.56	
H2 ¹⁾	=	11.48	

Projectile

G1 ¹⁾	=	10.72	
G2	=		
F	=		
L3+G ¹⁾	=	80.64	

Pressures (Energies)**Method Transducer**

Pmax	=	3650 bar	
PK	=	4198 bar	
PE	=	4560 bar	
M	=	25.00	
EE	=	6815 Joule	

Miscellaneous Dimensions

Fe ¹⁾	=	0.15	
delta L	=		

CHAMBER MINI**Lengths**

L1*	=	50.77	
L2*	=	57.13	
L3 ¹⁾	=	73.33	

Breech

R	=	1.27	
R1	=	13.84	
R2	=		
R3	=		
r	=		

Powder Chamber

E	=	3.30	
P1 ¹⁾	=	13.87	
P2*	=	13.49	

Junction Cone

alpha ¹⁾	=	17°04'45"	
S	=	95.69	
r1 max	=		
r2	=		

Collar

H1*	=	11.58	
H2 ¹⁾	=	11.51	

Commencement of Rifling

G1 ^{1)*}	=	10.77	
G ^{1)*}	=	7.62	
alpha1	=	90°	
h*	=	0.37	
s	=		
i ¹⁾	=	1°13'29"	
w	=		

Barrel

F ^{1)*}	=	10.46	
Z ¹⁾	=	10.77	

Grooves

b	=	3.50	
N	=	6	
u	=	420.00	
Q	=	89.25	mm ²

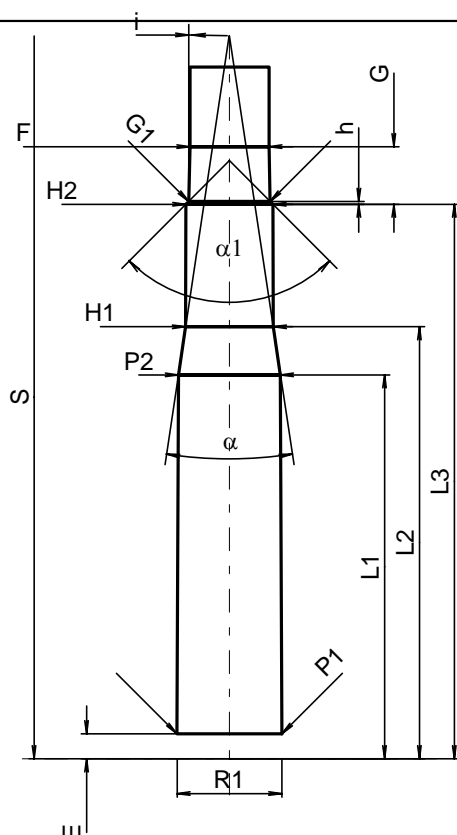

Scale 1:1

Dimensions in << mm >>
Dimensions and Tolerances for Proof Barrels
see Appendix CR 1.

Notes: 1) Check for safety reasons
* Basic dimensions