

C.I.P.**7 mm Rem. SA Ultra Mag.**

TAB.	I
Datum	02-03-01
Revision	04-09-27

Ursprungsland: US

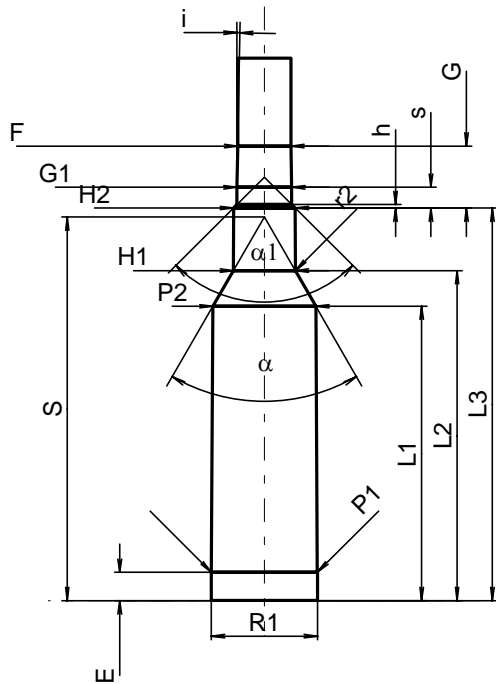
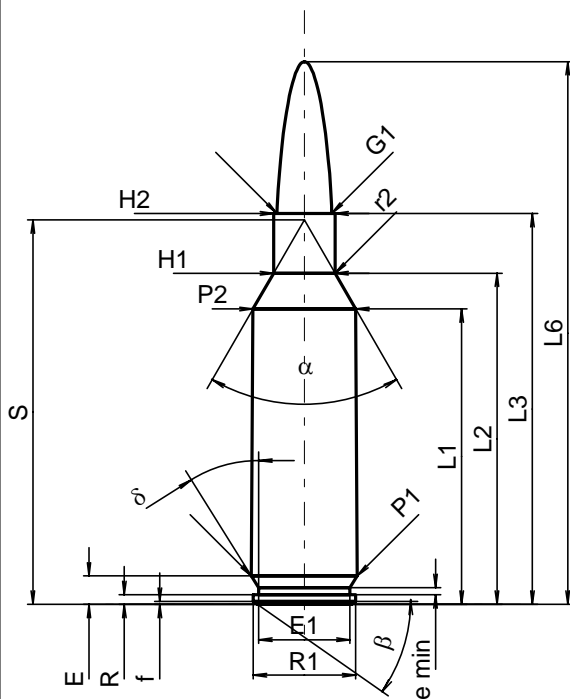

Maßstab 1:1

Maße in << mm >>
Maße und Toleranzen für Messläufe
siehe Anhang CR 1.

PATRONE MAXI**Längen**

L1 ¹⁾	=	39.07	-0.20
L2 ¹⁾	=	43.79	-0.20
L3 ¹⁾	=	51.69	
L4	=		
L5	=		
L6	=	71.76	

Hülsenboden

R	=	1.27
R1	=	13.56
R3	=	
E	=	3.75
E1	=	12.07
e min	=	0.94
delta	=	32°
f	=	0.41
beta	=	35°

Pulverkammer

P1	=	14.00	
P2 ^{1)*}	=	13.58	-0.20

Schulterkonus

alpha*	=	60°
S*	=	50.83
r1 min	=	
r2	=	3.18

Hülsenhals

H1*	=	8.13
H2 ¹⁾	=	8.13

Geschoss

G1 ¹⁾	=	7.23
G2	=	7.04
F	=	
L3+G ¹⁾	=	59.88

Drücke (Energien)**Mech. elektr. Wandler**

Pmax	=	4400 bar
PK	=	5060 bar
PE	=	5500 bar
M	=	25.00
EE	=	4500 Joule

Verschiedene Daten

Fe	=	0.10
delta L	=	0.10

PATRONENLAGER MINI**Längen**

L1	=	38.95
L2	=	43.65
L3 ¹⁾	=	51.94

Stoßboden

R	=	
R1	=	14.05
R2	=	
R3	=	
r	=	

Pulverkammer

E	=	3.75
P1 ¹⁾	=	14.01
P2*	=	13.61

Schulterkonus

alpha ^{1)*}	=	60°
S*	=	50.74
r1 max	=	
r2	=	3.18

Hülsenhals

H1*	=	8.18
H2 ¹⁾	=	8.15

Geschossübergang

G1 ^{1)*}	=	7.23
G ¹⁾	=	8.19
alpha1*	=	90°
h	=	0.46
s	=	2.75
i ^{1)*}	=	1°
w	=	

Lauf

F ^{1)*}	=	7.04
Z ¹⁾	=	7.21

Züge

b	=	2.79
N	=	6
u	=	254.00
Q	=	40.39 mm ²

Bemerkungen: 1) Kontrolle aus Sicherheitsgründen
* Grundmaße