

C.I.P.**416 Rigby**

Ursprungsland: GB

TAB.	I
Datum	84-06-14
Revision	02-05-15

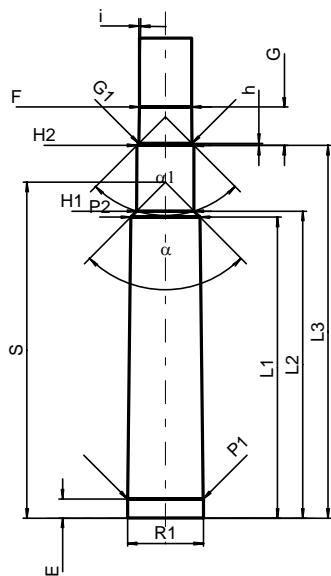
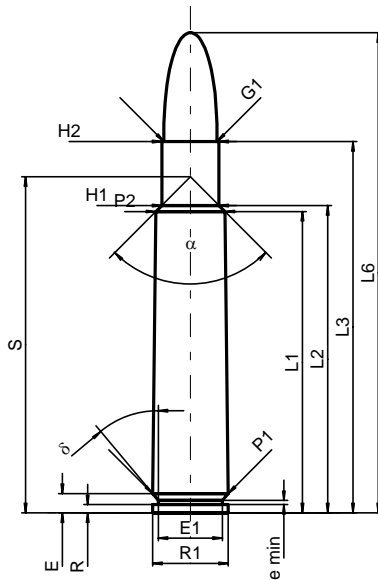

Maßstab 1:1.5

Maße in << mm >>
Maße und Toleranzen für Messläufe
siehe Anhang CR 1.

PATRONE MAXI**Längen**

L1 ^{1)*}	=	59.77	-0.20
L2 ^{1)*}	=	60.96	-0.20
L3 ¹⁾	=	73.66	
L4	=		
L5	=		
L6	=	95.25	

Hülsenboden

R	=	1.65	
R1	=	14.99	
R3	=		
E	=	3.81	
E1	=	12.70	
e min	=	0.81	
delta	=	39°55'48"	
f	=		
beta	=		

Pulverkammer

P1	=	14.96	
P2 ^{1)*}	=	13.72	-0.20

Schulterkonus

alpha	=	89°45'32"	
S	=	66.66	
r1 min	=		
r2	=		

Hülsenhals

H1 *	=	11.35	
H2 ¹⁾	=	11.33	

Geschoss

G1 ¹⁾	=	10.57	
G2	=		
F	=		
L3+G ¹⁾	=	81.28	

Drücke (Energien)**Mech. elektr. Wandler**

Pmax	=	3250 bar	
PK	=	3738 bar	
PE	=	4060 bar	
M	=	25.00	
EE	=	7270 Joule	

Verschiedene Daten

Fe ¹⁾	=	0.15	
delta L	=		

PATRONELAGER MINI**Längen**

L1 *	=	59.72	
L2 *	=	60.91	
L3 ¹⁾	=	73.96	

Stoßboden

R	=	1.65	
R1	=	15.04	
R2	=		
R3	=		
r	=		

Pulverkammer

E	=	3.81	
P1 ¹⁾	=	14.99	
P2 *	=	13.74	

Schulterkonus

alpha ¹⁾	=	89°30'59"	
S	=	66.65	
r1 max	=		
r2	=		

Hülsenhals

H1 *	=	11.38	
H2 ¹⁾	=	11.35	

Geschossübergang

G1 ^{1)*}	=	10.59	
G ^{1)*}	=	7.62	
alpha1	=	90°	
h *	=	0.38	
s	=		
i ¹⁾	=	0°54'36"	
w	=		

Lauf

F ^{1)*}	=	10.36	
Z ¹⁾	=	10.57	

Züge

b	=	3.60	
N	=	6	
u	=	420.00	
Q	=	86.61	mm ²

Bemerkungen: 1) Kontrolle aus Sicherheitsgründen
* Grundmaße