

C.I.P.

9,3 RSM

Country of Origin: DE

TAB. I

Date 11-05-25

Revision

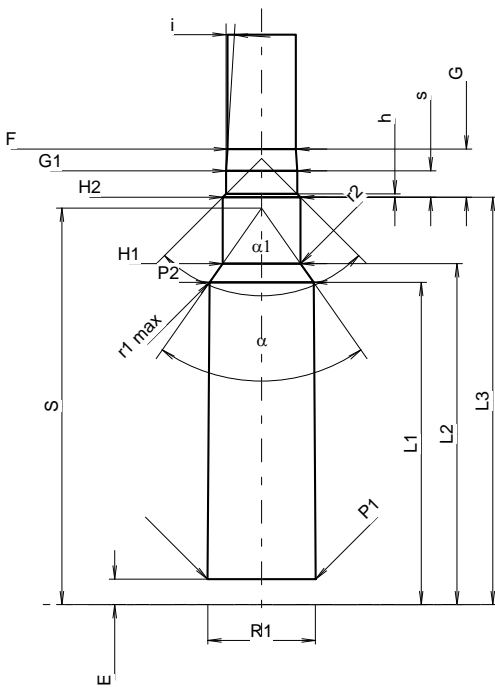
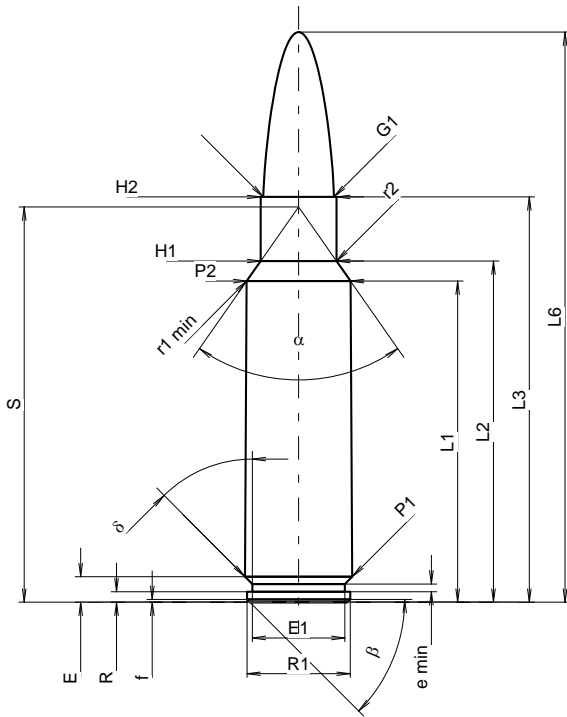

Scale 1.01:1

Dimensions in << mm >>
Dimensions and Tolerances for Proof Barrels
see Appendix CR1.

CARTRIDGE MAXI

Lengths

L1 ¹⁾	=	42.24	-0.20
L2 ¹⁾	=	44.88	-0.20
L3 ¹⁾	=	53.32	
L4	=		
L5	=		
L6	=	75.00	

Case Head

R	=	1.37	
R1	=	13.59	
R3	=		
E	=	3.36	
E1	=	12.19	
e min	=	1.02	
delta	=	45°	
f	=	0.36	
beta	=	45°	

Powder Chamber

P1	=	14.12	
P2 ¹⁾ *	=	13.67	-0.20

Junction Cone

alpha *	=	70°	
S *	=	52.00	
r1 min	=	0.80	
r2	=	2.54	

Collar

H1 *	=	9.98	
H2 ¹⁾	=	9.98	

Projectile

G1 ¹⁾	=	9.30	
G2	=		
F	=		
L3+G ¹⁾	=	59.66	

Pressures (Energies)

Method Transducer

Pmax	=	4400 bar	
PK	=	5060 bar	
PE	=	5720 bar	
M	=	25.00	
EE	=	5250 Joule	

Miscellaneous Dimensions

Fe ¹⁾³⁾	=	0.10	
delta L	=		

CHAMBER MINI

Lengths

L1	=	42.40	
L2	=	44.87	
L3 ¹⁾	=	53.59	

Breech

R	=	1.37	
R1	=	14.13	
R2	=		
R3	=		
r	=		

Powder Chamber

E	=	3.36	
P1 ¹⁾	=	14.25	
P2 *	=	13.70	

Junction Cone

alpha ¹⁾ *	=	70°	
S *	=	52.18	
r1 max	=	1.27	
r2	=	3.05	

Collar

H1 *	=	10.24	
H2 ¹⁾	=	10.24	

Commencement of Rifling

G1 ¹⁾ *	=	9.35	
G ¹⁾	=	6.34	
alpha1	=	90°	
h	=	0.45	
s	=	3.48	
i ¹⁾ *	=	3°30'	
w	=		

Barrel

F ¹⁾ *	=	9.00	
Z ¹⁾	=	9.28	

Grooves

b	=	4.60	
N	=	6	
u	=	406.40	
Q	=	67.67	mm ²

Notes: 1) Check for safety reasons
3) Headspace on Shoulder
* Basic dimensions