

**C.I.P.****6,5 Creedmoor**

TAB. I

Date 12-05-30

Pays d'origine: US

Révision

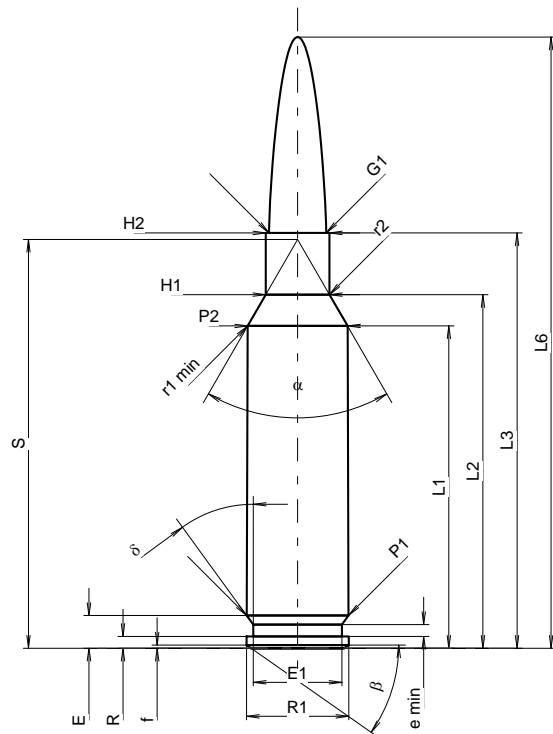
**CARTOUCHE MAXI****Longueurs**

L1 <sup>1)</sup>	=	37.84	-0.20
L2 <sup>1)</sup>	=	41.52	-0.20
L3 <sup>1)</sup>	=	48.77	
L4	=		
L5	=		
L6	=	71.76	

**Culot**

R	=	1.37	
R1	=	12.01	
R3	=		
E	=	3.84	
E1	=	10.39	
e min	=	1.40	
delta	=	36°	
f	=	0.38	
beta	=	35°	

**Chambre à poudre**

P1	=	11.95	
P2 <sup>1)</sup> *	=	11.74	-0.20

**Cône de raccordement**

alpha *	=	60°	
S *	=	48.01	
r1 min	=	0.76	
r2	=	3.18	

**Collet**

H1 *	=	7.49	
H2 <sup>1)</sup>	=	7.49	

**Projectile**

G1 <sup>1)</sup>	=	6.72	
G2	=		
F	=		
L3+G <sup>1)</sup>	=	58.42	

**Pressions (Énergies)****Méthode transducteur**

Pmax	=	4350 bar	
PK	=	5003 bar	
PE	=	5438 bar	
M	=	25.00	
EE	=	3400 Joule	

**Autres indications**

Fe <sup>1)3)</sup>	=	0.10	
delta L	=	0.06	

**CHAMBRE MINI****Longueurs**

L1	=	37.76	
L2	=	41.42	
L3 <sup>1)</sup>	=	48.90	

**Cuvette**

R	=		
R1	=	12.01	
R2	=		
R3	=		
r	=		

**Chambre à poudre**

E	=	3.84	
P1 <sup>1)</sup>	=	11.98	
P2 *	=	11.76	

**Cône de raccordement**

alpha <sup>1)</sup> *	=	60°	
S *	=	47.95	
r1 max	=	0.76	
r2	=	3.18	

**Collet**

H1 *	=	7.54	
H2 <sup>1)</sup>	=	7.52	

**Prise de rayures**

G1 <sup>1)</sup> *	=	6.72	
G <sup>1)</sup>	=	9.65	
alpha l	=	90°	
h	=	0.40	
s *	=	5.45	
i <sup>1)</sup> *	=	1°30'	
w	=		

**Canon**

F <sup>1)</sup> *	=	6.50	
Z <sup>1)</sup>	=	6.71	

**Rayures**

b	=	2.29	
N	=	6	
u	=	203.00	
Q	=	34.66	mm <sup>2</sup>

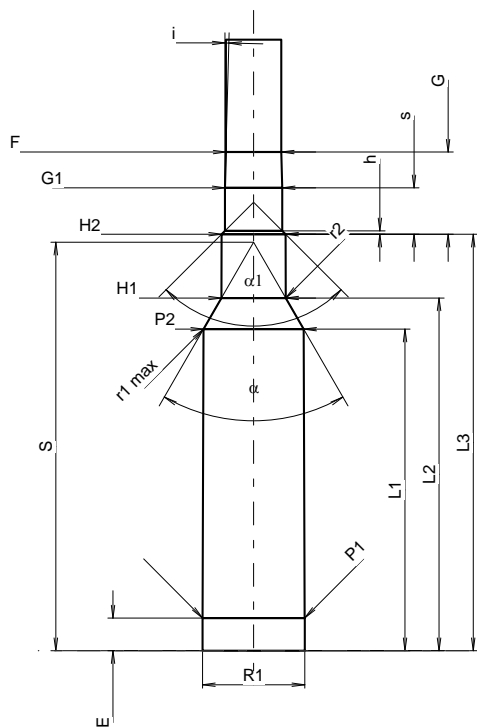

Échelle 1.13:1

Dimensions en << mm >>  
Dimensions et tolérances pour les canons  
d'épreuve: Voyez Annexe CR1.

Notes: 1) A' contrôler pour la sécurité  
3) Feuillure sur la cone de raccordement  
\* Dimensions de base