

C.I.P.

17 Rem. Fireball

Country of Origin: US

TAB. I

Date 08-04-15

Revision 11-05-25

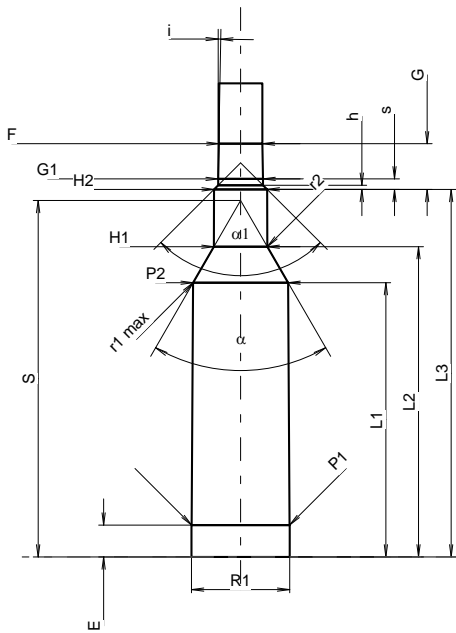
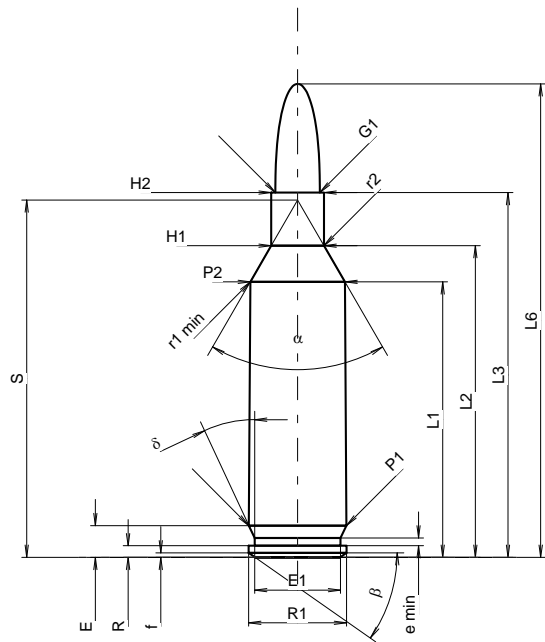

Scale 1.35:1

CARTRIDGE MAXI

Lengths

L1 ¹⁾	=	27.05	-0.20
L2 ¹⁾	=	30.60	-0.20
L3 ¹⁾	=	35.81	
L4	=		
L5	=		
L6	=	46.48	

Case Head

R	=	1.14	
R1	=	9.60	
R3	=		
E	=	3.12	
E1	=	8.43	
e min	=	0.76	
delta	=	25°	
f	=	0.45	
beta	=	35°	

Powder Chamber

P1	=	9.57	
P2 ¹⁾ *	=	9.28	-0.20

Junction Cone

alpha *	=	60°	
S *	=	35.08	
r1 min	=	0.64	
r2	=	2.54	

Collar

H1 *	=	5.18	
H2 ¹⁾	=	5.18	

Projectile

G1 ¹⁾	=	4.38	
G2	=		
F	=		
L3+G ¹⁾	=	40.29	

Pressures (Energies)

Method Transducer

Pmax	=	3800 bar	
PK	=	4370 bar	
PE	=	4750 bar	
M	=	17.50	
EE	=	980 Joule	

Miscellaneous Dimensions

Fe ¹⁾	=	0.15	
delta L	=	0.11	

CHAMBER MINI

Lengths

L1	=	26.92	
L2	=	30.45	
L3 ¹⁾	=	36.07	

Breech

R	=		
R1	=	9.63	
R2	=		
R3	=		
r	=		

Powder Chamber

E	=	3.12	
P1 ¹⁾	=	9.60	
P2 *	=	9.31	

Junction Cone

alpha ¹⁾ *	=	60°	
S *	=	34.98	
r1 max	=	0.64	
r2	=	3.18	

Collar

H1 *	=	5.23	
H2 ¹⁾	=	5.21	

Commencement of Rifling

G1 ¹⁾ *	=	4.39	
G ¹⁾	=	4.48	
alpha 1 *	=	90°	
h	=	0.41	
s	=	1.04	
i ¹⁾ *	=	1°	
w	=		

Barrel

F ¹⁾ *	=	4.27	
Z ¹⁾	=	4.37	

Grooves

b	=	1.57	
N	=	6	
u	=	228.60	
Q	=	14.80	mm ²

Notes: 1) Check for safety reasons
* Basic dimensions

Dimensions in << mm >>
Dimensions and Tolerances for Proof Barrels
see Appendix CR 1.